



ENCORE™ REVERSE DYAD OPERATOR

Drawings begin on pg. 26r

- Uniquely designed for narrow windows and specialty windows like round tops, half round, trapezoid, garden, octagon and windows that require Butt Hinges.
- Will work on frame widths down to a minimum of 12" depending upon the thickness of the frame.
- Uses a non-handed bracket which will help reduce inventory issues.

ORDERING INFORMATION:

1. Specify "standard" or "coastal" package.
2. Order item number:
#50.80 or
#50.81 (low profile) or
#50.82 (rear-mount)
3. Specify finish number.
4. Specify right- or left-hand (determined by the side the hinge is on when viewed from the outside).
5. Select mounting hardware (sold separately).

#11674.XX – Non-Handed Bracket
Optional brackets for unique profile applications are available – see Truth's Stud Bracket & Track section, or contact Truth Hardware for further details.

Tango™ Style Cover & Handle pack (handed*)

- #12614.XX** – Left-hand
- #12616.XX** – Right-hand

***NOTE:** Handle & cover handing is determined by direction the handle points in the nested position.

Optional accessories:

- #32658** – Gasket
- #31883** – Gasket Applicator
- #21969.92** – Backplate (required for Rear mount options)
- #21306** – Protective red plastic spline cap.



ENCORE™ SINGLE ARM OPERATOR

Drawings begin on pg. 26x

- Created for casements which are 20"-32" wide up to 72" high and with a 73lb. sash weight.
- Fits in all profiles currently using the EntryGard® or Maxim® Single Arm operators.

ORDERING INFORMATION:

1. Specify "standard" or "coastal" package.
 2. Order item number:
#52.11 or
#52.13 (low profile)
- Note:** Rear-mount version available upon request.
3. Specify finish number.
 4. Specify right- or left-hand (determined by the side the hinge is on when viewed from the outside).
 5. Select mounting hardware (sold separately).

- #11576.XX** – Track & Slider, or
- #30175** – Low profile track

Tango™ Style Cover & Handle pack (handed*)

- #12614.XX** – Left-hand
- #12616.XX** – Right-hand

***NOTE:** Handle & cover handing is determined by direction the handle points in the nested position.

Optional accessories:

- #32658** – Gasket
- #31883** – Gasket Applicator
- #21306** – Protective red plastic spline cap.

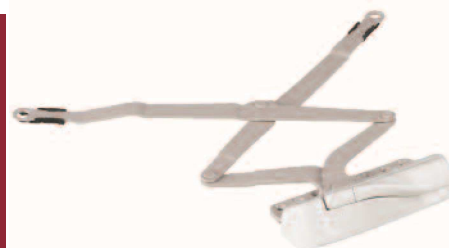

ENCORE™ AWNING OPERATORS

Drawings begin on pg. 26ee and 26hh

- Allows the manufacturer to offer the same look throughout the home on both casements and awnings.
- Will provide for maximum opening combined with wide "pull-in" connection to sash.
- Operates frame widths from 20" to 60", reducing inventory requirements for operator sizes.
- New narrow gauge version (#51.13) fits smaller cavity profiles and smaller window sizes.
- "Quick disconnect" feature on operator arms does not require tools.

ORDERING INFORMATION:

1. Specify "standard" or "coastal" package.
2. Order Operator item number:
#51.10 or
#51.12 (rear-mount) or
#51.11 (narrow awning)
3. Specify finish number.
4. Select mounting hardware (sold separately).

#11577.XX – Track and Pivot Slides
Tango™ Style Cover & Handle pack (handed*)

- #12614.XX** – Left-hand

***NOTE:** Handle & cover handing is determined by direction the handle points in the nested position.

Optional accessories:

- #32658** – Gasket
- #31883** – Gasket Applicator
- #21969.92** – Backplate (required for Rear mount options)
- #21306** – Protective red plastic spline cap.

ENCORE™ AWNING OPERATOR (SILL MOUNT)

FIG. 1 APPLICATION OF ENCORE AWNING OPERATOR (SILL MOUNT VERSION)

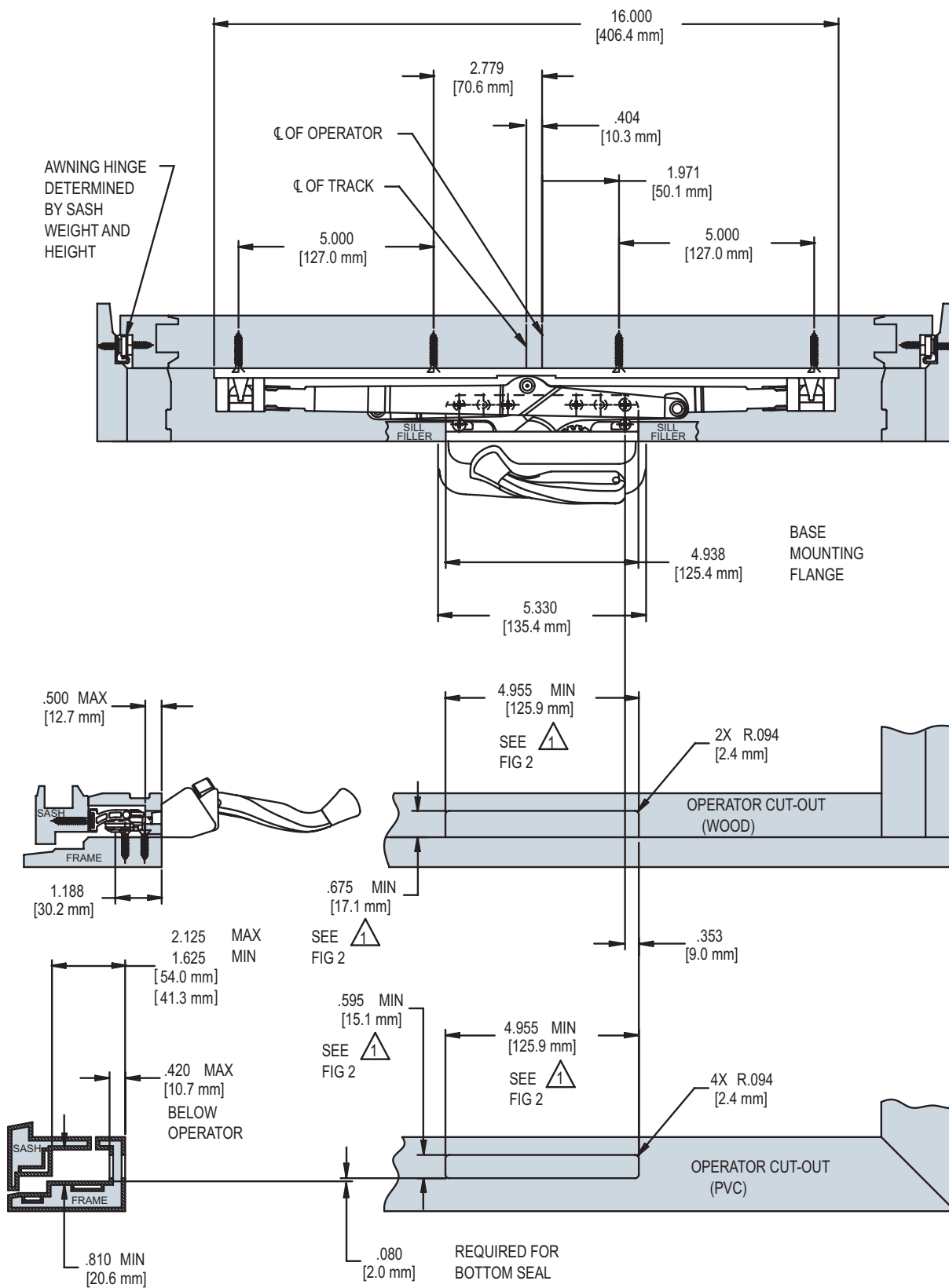

**FIG. 2 APPLICATION OF ENCORE AWNING OPERATOR CONTINUED
(SILL MOUNT VERSION)**

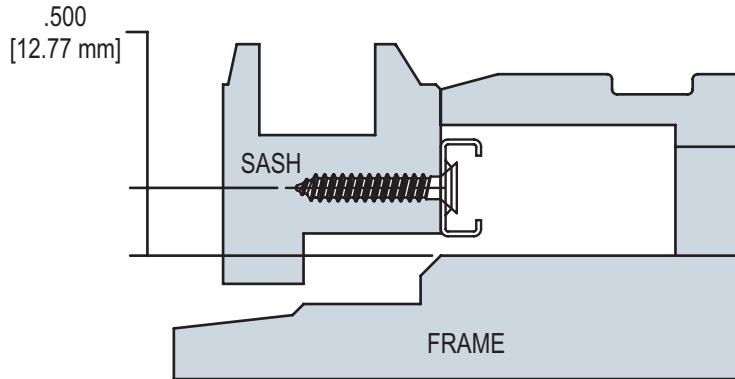

**11577.92
TRACK PLACEMENT**

| HARDWARE SHOWN FOR LEFT HAND WINDOW, SEE FIG. 1 | |
|---|-------------------------|
| PART NUMBER | DESCRIPTION |
| 51.10.00.X11 | AWNING OPERATOR |
| 11577.XX | TRACK ASSEMBLY |
| 13.XX.XX.XXX | HINGE |
| 12614.XX | TANGO HANDLE/COVER PACK |
| 32658 | GASKET (PVC) |

NOTE:

1. HOLD THIS DIMENSION AS CLOSE TO THE MINIMUM AS MANUFACTURING TOLERANCES ALLOW. A CLOSE FITTING CUT-OUT HELPS TO STABILIZE THE OPERATOR AGAINST ROCKING

2. GASKET 32658 IS REQUIRED ON PVC AND METAL PROFILES FOR AN IMPROVED AIR AND WATER SEAL

3. ALL AWNING OPERATORS USE 12614.XX LEFT HAND TANGO HANDLE/COVER PACK

ENCORE™ AWNING OPERATOR (SILL MOUNT)

FIG. 3 ENCORE AWNING OPERATOR (SILL MOUNT VERSION)

STAINLESS STEEL VERSION AVAILABLE

51.10.XX.011 SHOWN

51.12 REAR MOUNT VERSION ALSO AVAILABLE

RECOMMENDED SCREWS:

(QTY 6)(PN 19240.XX)#8 X 1 FLAT HEAD SHEET METAL SCREW (SEE TRUTH TIPS FOR MORE INFORMATION)

(QTY 2)REAR MOUNT:#8-32 X 3/8 PAN HEAD MACHINE SCREW PN 19545.XX

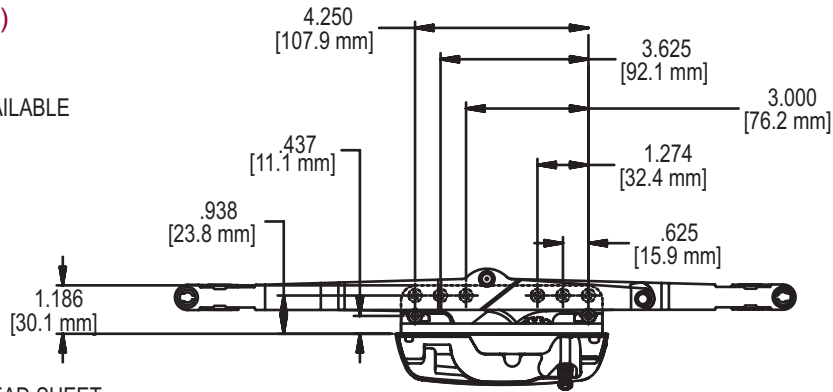

FIG. 4 ENCORE TANGO HANDLE/COVER 12614.XX(LH) (SHOWN), 12616.XX(RH)

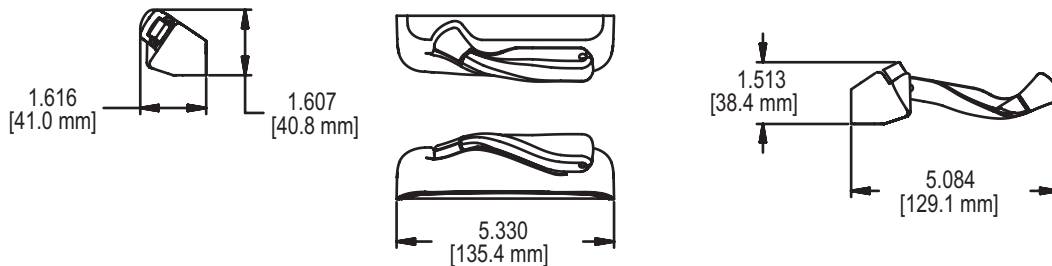

FIG. 5 BACK PLATE 21969.92

FOR USE WITH 51.12 REAR MOUNT VERSION ONLY

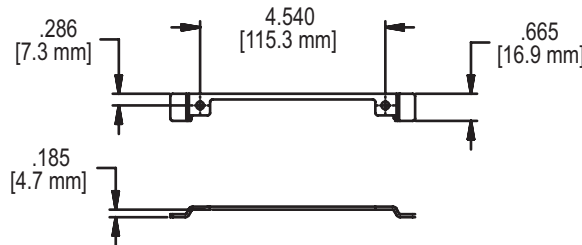
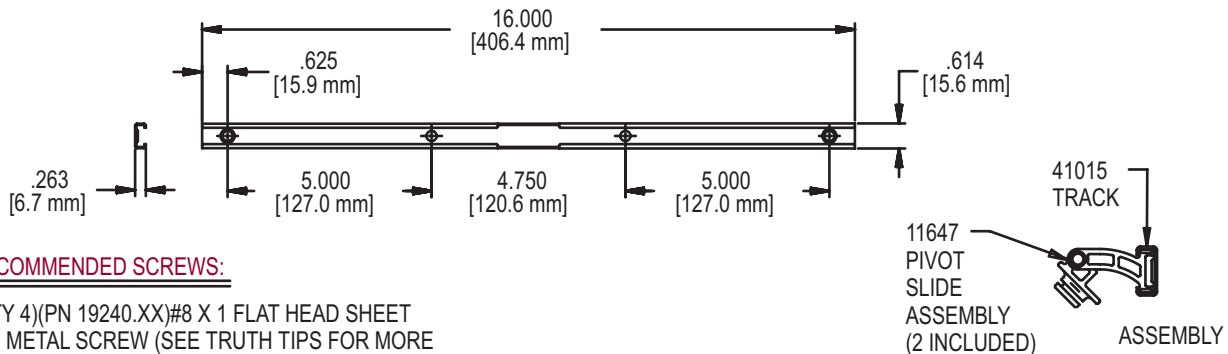

FIG. 6 ENCORE AWNING TRACK & SLIDER ASSEMBLY 11577.XX

STAINLESS STEEL VERSION AVAILABLE



RECOMMENDED SCREWS:

(QTY 4)(PN 19240.XX)#8 X 1 FLAT HEAD SHEET METAL SCREW (SEE TRUTH TIPS FOR MORE INFORMATION)